

According to Continental Controls Corp., because the GV1 is actuated with a voice-coil, it is fast acting and has very little stiction or hysteresis.

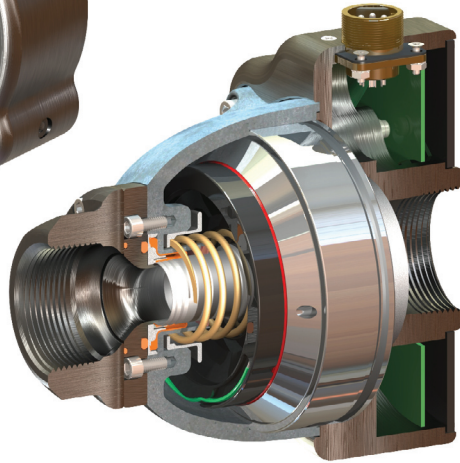

METERING FUEL FOR AFR CONTROL ON GAS ENGINES

Continental Controls Introduces GV 1
Electronic Fuel Valve

By Brent Haight

Targeting gas engines from 50 to 500 hp (37 to 373 kW), Continental Controls Corp. has introduced the GV 1 electronic fuel valve.

"Gas engines are now required to control the ratio of air and fuel in order to lower emissions and improve engine efficiency," said Rick Fisher, vice president of sales and marketing at Continental Controls. Headquartered in San Diego, California, U.S.A., Continental Controls Corp. specializes in fuel control products for both gas engines and gas turbine engines. "In the past, the small engines [less than 500 hp (373 kW)] were generally exempt. Now more and more are getting included in new emission requirements. On the gas engine side, it's primarily been emissions driven although there is also an interest in improving engine efficiency, and we can often help on both fronts.

"The GV 1 is designed specifically to control gaseous fuels for small to mid-sized gas engines. Current designs in the market are extremely slow reacting. The GV 1 goes full range in 30 milliseconds with almost no stiction or

hysteresis an infinite number of steps in resolution," said Fisher. "We are utilizing a new generation of technology. We have a design that is voice-coil actuated, which allows the valve to be not only fast but extremely long lasting. Previous valves used for air-fuel ratio control don't allow you to react to changes in load or even changes in heating value of the gas very quickly."

According to Fisher, past solutions often involved adopting a valve designed for another application, not necessarily for natural gas or for the specific flows and pressures required for stationary gas engines.

"This resulted in unreliable valves that offered only a limited range of control and valves that often stick or malfunction," said Fisher. "In the past, there wasn't much verification of emissions compliance for gas engines. As the EPA and state agencies begin enforcing continuous emissions compliance, the fuel control valve technology becomes more central to long-term compliance.

"The electronics to manage the AFR control is sometimes integrated into

a stand-alone driver or controller and sometimes it is included in an engine control system or a PLC [programmable logic controller]. In all of these cases, a common problem has been how to control the amount of fuel to the engine.

"Companies that are good at creating an electronic box to control the AFR often still have to go out and find a valve that will work from their device to control the gas. We are the opposite. We are a gas valve company," said Fisher. "We start off thinking about the valve and how to make it smooth acting and fast."

The GV 1 is designed to be easily adapted to work with a variety of air-fuel ratio controls, carburetors or mixers, said Fisher. It can be controlled with a PLC. It works with turbocharged or naturally aspirated engines and can be used with a variety of gas types such as biogas, landfill gas and field gas as well as standard natural gas. Operating temperatures are -40° to 185°F (-40° to 85°C). The GV 1 is designed to be Class 1 Div. 2 compliant. For turbocharged applications, the GV 1 can operate from zero to 2 psi (zero to 0.14 bar) above boost pressure.

"There is customization available to this. This valve is designed for OEMs and packagers, and we are happy to modify it for their specific needs," said Fisher. "For example, the inlet and outlet adapters can be modified for 1 in. [2.5 cm] pipe, or 1.5 in. [3.8 cm] pipe. As far as electrical, the customer might have certain things they want. If an OEM came to us with a specific need, we would make a special version of this valve as long as it's feasible to include that requirement or feature."

The valve will include an integrated pressure transducer. Fisher said the GV 1 will operate as an electronic variable pressure control valve with zero droop.

"The concept is that using our valve, people who want to do their own air-fuel ratio on their PLC or their panel can use the GV 1 to be their interface to the engine," said Fisher.

The GV 1 brings a slight change to Continental Controls' product portfolio. The company has made its name offering high-end, highly integrated, complex products.

"The GV 1 takes us in a different direction than we have historically gone," said Fisher. "Traditionally, a company's products tend to evolve from a simple product to a very complex product. You build a base of simple products and eventually come up to a very complex product. As a company, we have gone the opposite direction. Our product line has targeted complex, very specialized products in the past. With the GV 1, we will expand our portfolio to now include a broader baseline of products." ©