

FOR GAS TURBINE FT10 FUEL CONTROL MANIFOLD

Natural Gas/Propane/Ethane/ Methane

FEATURES

**ALL STAINLESS STEEL
PIPING AND TUBING**

**PRE-ASSEMBLED AND
PRESSURE TESTED**

CLOSED IN <200 MS

**SPRING RETURN
(FAIL-SAFE)**

**SAFETY INTEGRITY
LEVEL (SIL) 2 TO 3**

**VENT VALVE FOR BLOCK
AND BLEED**

**FUEL TEMPERATURE
RANGE -40 °C TO +85 °C**

**BETTER THAN CLASS VI
SHUTOFF**

**COMPLICANT WITH
CSA, ATEX, PED, API**

**CERTIFIED PER ASME
SECTION 9 B31.1**

**CERTIFIED FOR USE IN
EXPLOSIVE
ATMOSPHERES**

**OPERATES FROM LINE
PRESSURE**

APPLICATION

The Fuel Train FT50 is designed to provide extremely fast shutoff of gaseous fuel flow to an industrial gas turbine engine. Gas flow is stopped when the valve is closed, or when pilot pressure is removed, with zero leakage from inlet to outlet. It is suitable for operation with gas temperatures between -40 and +185°F (-20 and +85°C).

The valve can achieve ANSI Class IV shut-off capability. The normally-closed valve may be used for emergency and normal shut own operation. Stainless steel construction assures availability of the valve despite corrosive service conditions or even catastrophic fire.

This product is suitable for use on industrial turbines up to 38,000 hp output range with single or multiple combustion fuel manifold systems.

DESCRIPTION

The Fuel Train isolation valve provides shutdown on a gas turbine by rapidly halting the flow of gaseous fuel. The supply pressure is used to move a spring-loaded piston in the valve. When the valve is energized, gas pressure drives the spring-loaded piston open, admitting fuel to the turbine. When the current signal to the electrical solenoid is interrupted, the spring loaded second-stage piston changes states to vent off primary control pressure. The main spring then forces the primary piston to the seal, stopping all flow. The pneumatic valve, pilot valve for pneumatic and ¼" vent valve are normally closed valves



SPECIFICATION

Performance:	Closing Time Within 0.200 second
Operating Conditions / Environment	
Chemical Compatibility:	NACE Compliant for all typical gas fuels
Fuel Temperature:	-40 °C to +85 °C
Ambient Temperature:	-40 °C to +85 °C
Fuel Types:	Natural gas, propane, ethane, methane
Fuel Supply Pressure:	Normal operation 150 to 500 psig
Fuel Solid Particle Contaminant:	<10 µm diameter, 30 ppm by volume
Pilot Filtration:	10 µm
Electrical Specifications	
Voltage available:	24 Vdc, 2 amps
Wiring Interface:	½-14 NPT conduit entry
Mechanical Specifications	
Inlet:	1-1/2" socket weld flange per ANSI B16.5; 600 lb
Outlet:	SAE Series 61 1-1/2" 4-bolt flange
Regulatory Compliance	
CSA:	CSA Certified for Class I Div 1 and Div 2, Groups C & D, T4
ATEX:	Declared to 94/9/EEC
PED:	PED 97/23/EC Module H
API:	API 607, ISO 10497
Safety Integrity Level (SIL):	IEC 61508-2 SIL 2/3
Valve Design:	ANSI B16.34, API 6D / ISO 14313, ISO 17292
H2S:	NACE MR-0175, ISO 15156-1/2/3

MECHANICAL CONSTRUCTION

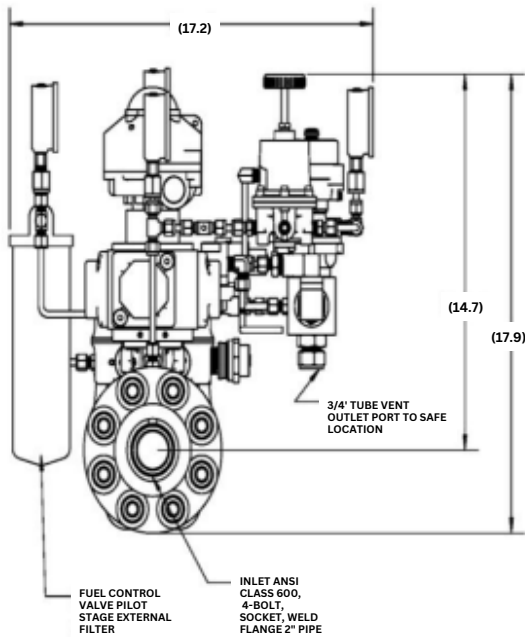
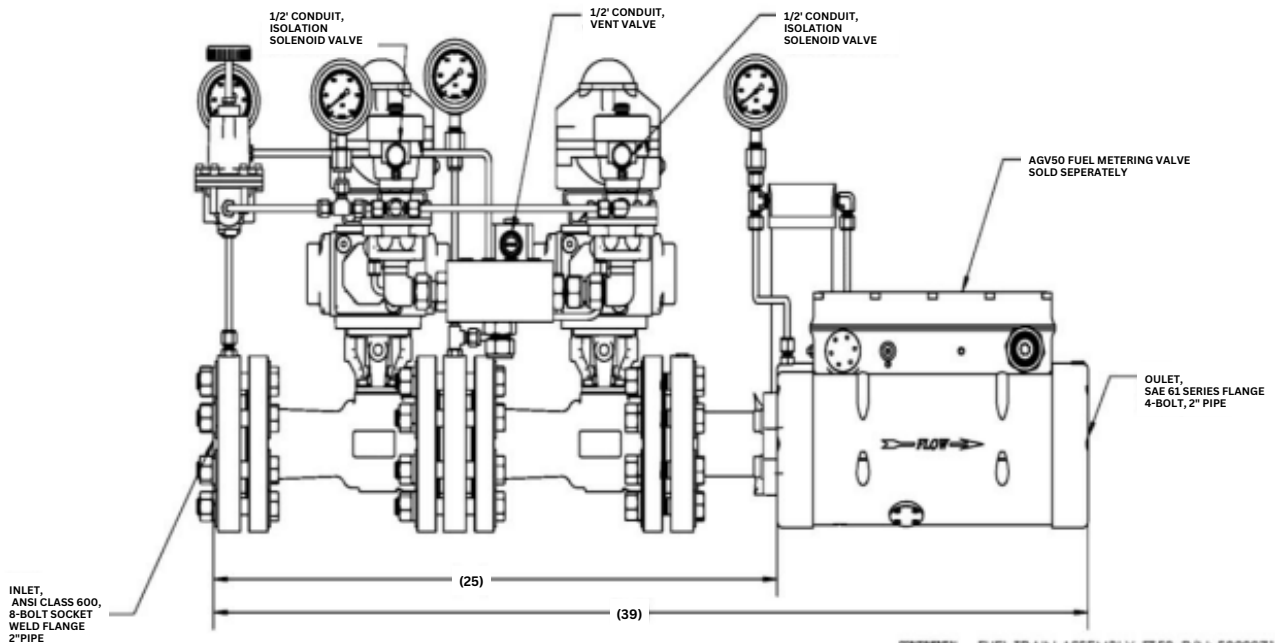
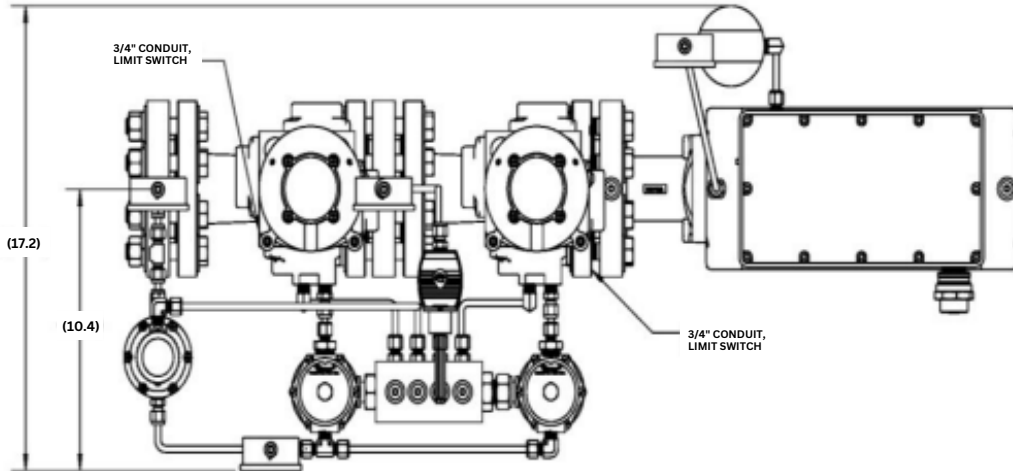

CONTINENTAL CONTROLS CORPORATION FUEL TRAIN ASSEMBLY, FT50, P/N: 50209718 ENVELOPE DRAWING



CONTINENTAL CONTROLS CORPORATION
7720 KENAMAR CT, SUITE C
SAN DIEGO, CALIFORNIA 92121 USA
PHONE: (858)453-9880 FAX: (858)453-3078
WWW.CONTINENTALCONTROLS.COM

04-26-2021



7710 Kenamar Court, San Diego, CA 92121

+1(858)453-9880

www.ContinentalControls.com

info.continentalcontrols.com