



FOR CONTROLLING EMISSIONS OF RICH BURN GAS ENGINE ELECTRONIC FUEL VALVE AND AIR-FUEL RATIO CONTROLLER GVI / AFR Natural Gas/ Propane / Bio-Fuels

ISO 9001: 2008 CERTIFIED
CSA CERTIFICATION PENDING

BENEFITS

SIMPLE AND COST-EFFECTIVE AFR CONTROL

FULL AUTHORITY

FUEL CONTROL

EXTREMELY FAST ACTING

FAST VARIABLE PRESSURE CONTROL

**SIZED FOR ENGINES
50hp TO 500hp
(DEPENDENT ON
SUPPLY PRESSURE)**

**WORKS WITH
TURBOCHARGED OR NA
ENGINES**

**USE WITH EXISTING
CARBURETOR OR VENTURI**

**GOOD FOR ALTERNATIVE
FUELS (BIO GAS, LANDFILL
GAS, FIELD GAS)**

LOW COST

THE CONTINENTAL CONTROLS SOLUTION

The GVI / AFR is one of the most simple and cost-effective Air-Fuel Ratio controllers for Natural Gas Engines. All electronics are built into the fuel valve. It does not require a separate display or electronic driver. All set up and communications will be via a notebook, a hand-held controller, or the optional mini HMI.

Often the solution has been to select a valve that was designed for another application or even another media (not necessarily for natural gas). Many times the valve was not designed for the specific flows and pressures for a specific stationary engine. This resulted in unreliable valves that offered only a limited range of control and valves that often would stick or malfunction. The GVI valve is designed specifically to control gaseous fuels for small to midsized engines. It is designed to control the AFR using variable pressure control based on an input from an oxygen sensor located prior to the catalyst in the engine exhaust.

It will offer full authority fuel control to allow for enough range to accommodate even low BTU field gas, bio gas, or landfill gas.

GV 1 / AFR with 1 1/2" pipe thread flanges.



CLOSED LOOP PRESSURE CONTROL

The GV₁/AFR consists of a pressure transducer, the electronic circuit, and a gas valve operated by a voice coil actuator. The transducer measures the gas injection pressure to its set-point and adjusts the current in the voice coil actuator to regulate the gas flow in order to maintain the pressure at its set-point. The control provides integral or “reset” control of the pressure, i.e. there is no droop in pressure as the flow increases.

Generally variable pressure control is regarded as one of the most effective techniques for controlling air fuel ratio to a gas engine. The O₂ sensor feedback is used to adjust the pressure set-point to maintain the desired air to fuel ratio.

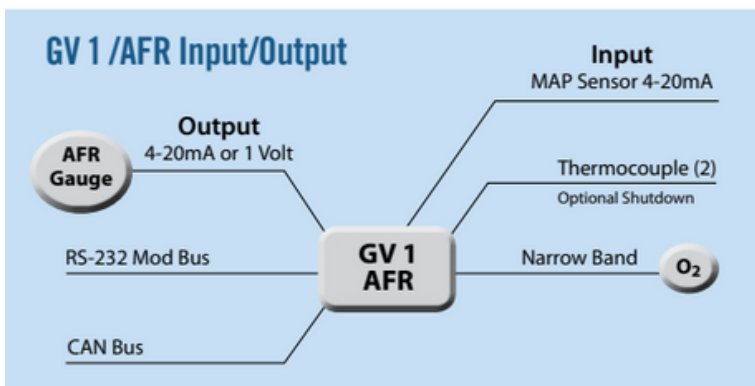
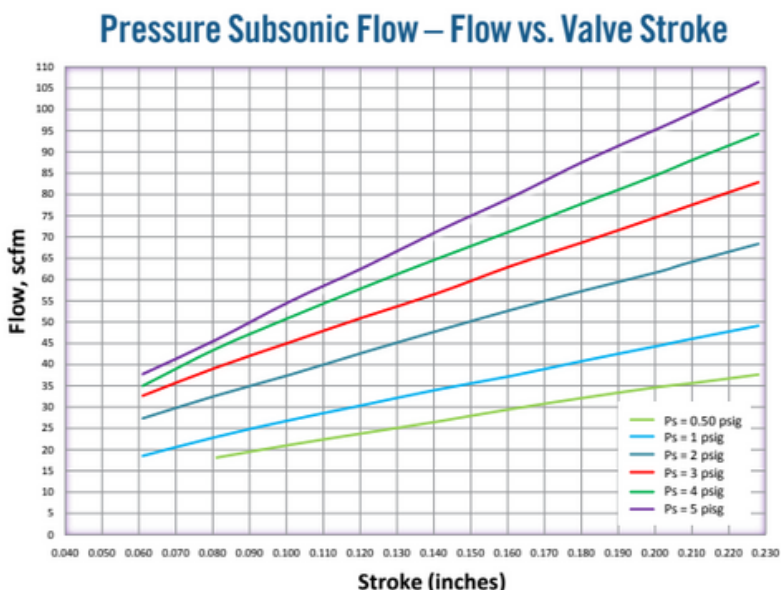

The GV 1 / AFR is simple yet effective.

COMMAND/ I/O

4-1Vdc O₂ Sensor

4-20mA MAP Sensor used to adjust the O₂ set-point based on load

RS-232 Mod Bus

CAN Bus J-1939

GAS SUPPLY PRESSURE

The GV₁ / AFR can operate at a maximum of 5 psi-dp pressure above turbo boost pressure. Max operating pressure is 32psi

OPERATING TEMPERATURE

From -40 to 185 Degrees F

PERFORMANCE

Response < 30 ms Full Stroke

Static Accuracy .2" w.c.

ADDITIONAL SPECIFICATIONS

10-30Vdc Input Power

28 psig Max Turbo Boost Pressure

1/4" NPT Port for Turbo Reference Line

HAZARDOUS ENVIRONMENT

Designed to be Class 1 Div 2 Compliant



7710 Kenamar Court, San Diego, CA 92121

+1(858)453-9880

www.ContinentalControls.com

info.continentalcontrols.com